

REUNAKIVEN ASENNUS 1:20 12cm, Det1

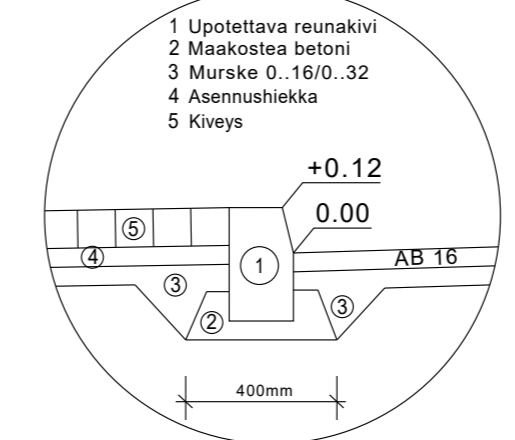

REUNAKIVEN ASENNUS 1:20 0/4cm, Det2

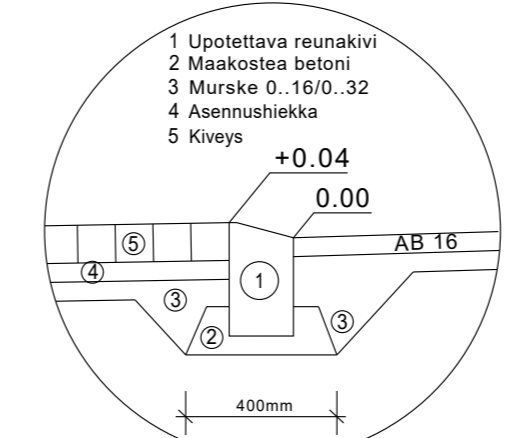

Koordinaattijärjestelmä ETRS-GK26	Kokoojärjestelmä N2000	KOHTEEN NIMI JA OSOITE KEMPELEEN KUNTA YLIKYLÄN LAATUKÄYTÄVÄ KATUSUUNNITELMA		Kokoojärjestelmä PIIRUSTUKSEN SISÄLTO Tyypipoikkeileikkaukset	MITTAKAAVA 1:100
SWECO		SULAN V. Pietarilla TARK. K. Veronen HYV.	TIEDOSTO	SUUNNALA	TYÖ N°
Sweco Ympäristö Oy Rautatiekatu 33, 90100 OULU • 0207 363 000		15.1.2021	YT	20602727	PIIR N° R3-1